

Technical Data – 5730 MV 490 FRAME PULL-UP SUBMERSIBLE, CENTERLINE DISCHARGE

CABLE

Power and control cable are UL Listed and CSA Approved.

ELECTRICAL CONNECTION

Double-seal system with strain relief, consisting of a rubber grommet followed by epoxy. Individual wires have the insulation removed prior to epoxy potting to prevent wicking into the motor.

Wires are terminated with connectors secured to bronze lugs on the O-ring sealed terminal board. Stator and control leads from the motor are attached to the underside of the lugs.

SHAFT

Solid 416 stainless steel, precision machined to ensure a tight fit of the impeller and rotor onto the shaft.

MECHANICAL SEALS

Two separate tandem mounted seals to protect the motor from the pumped liquid. Upper seal is carbon against ceramic faces. Lower seal is silicon carbide against tungsten carbide faces.

STAINLESS STEEL BOLTS

External bolts are stainless steel for ease of maintenance.

IMPELLER

Enclosed axial flow design with blunt rounded leading edges and thick hydrofoil shape to pass large solids and stringy material. One-piece cast impellers are designed for circular flow to match in the equalizing-pressure, thick walled volute.

WEAR RINGS

Impeller and volute may be fitted with axial wear rings hardened to 300–350 Bhn or higher stainless steel.

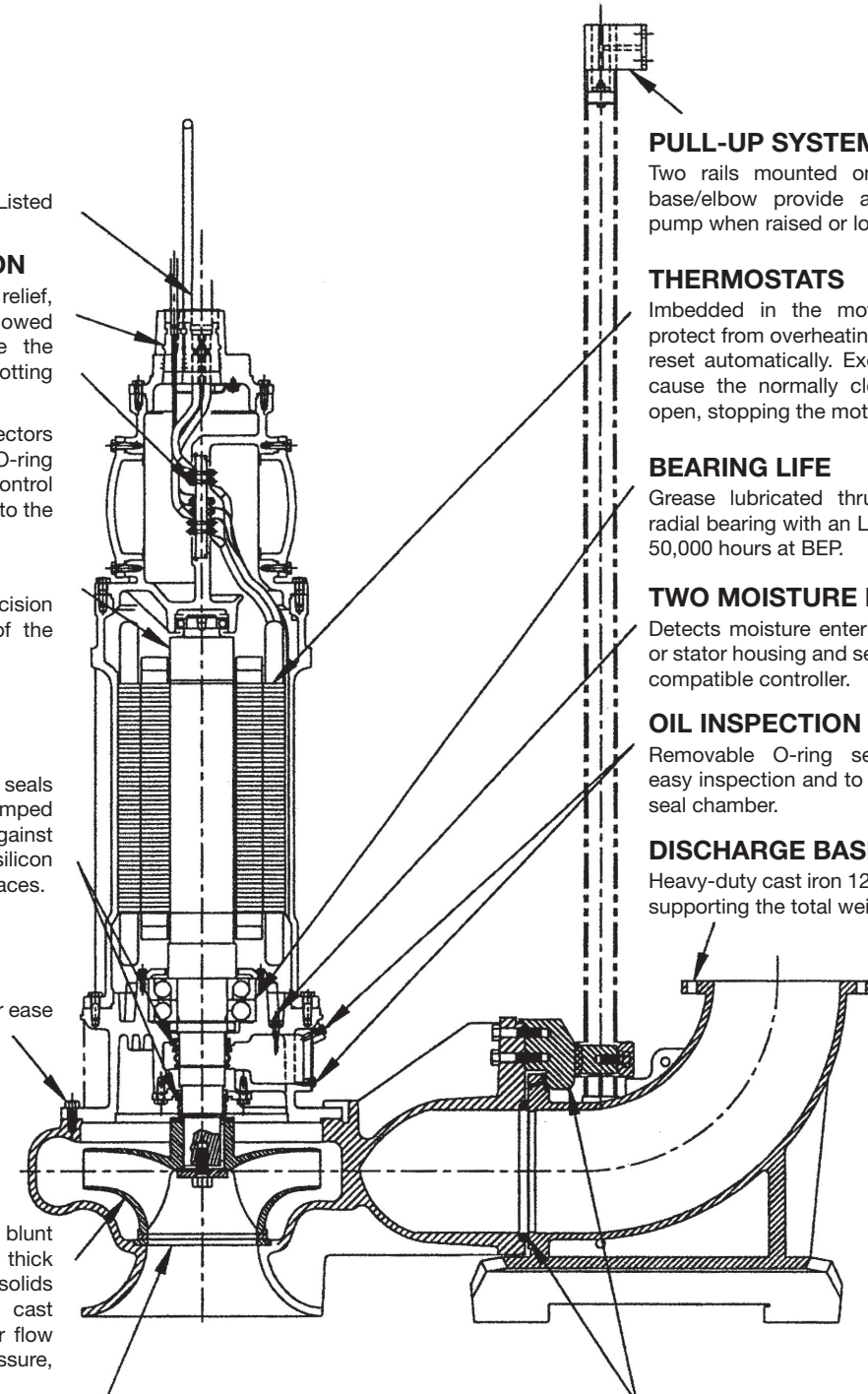

PULL-UP SYSTEM

Two rails mounted on the discharge base/elbow provide a guide for the pump when raised or lowered.

THERMOSTATS

Imbedded in the motor windings to protect from overheating. These devices reset automatically. Excessive heat will cause the normally closed contact to open, stopping the motor.

BEARING LIFE

Grease lubricated thrust bearing and radial bearing with an L10 bearing life of 50,000 hours at BEP.

TWO MOISTURE DETECTORS

Detects moisture entering the oil cavity or stator housing and sends a signal to a compatible controller.

OIL INSPECTION PLUGS

Removable O-ring sealed plugs for easy inspection and to change oil in the seal chamber.

DISCHARGE BASE/ELBOW

Heavy-duty cast iron 125 lb. ANSI flange supporting the total weight of the pump.

SLIDING BRACKET ASSEMBLY

Non-sparking, UL Listed hazardous location bronze. When lowered onto the discharge base/elbow, a knifing action of the vertical metal-to-metal, self-cleaning connection is secured.

Technical Data – 5730 W 490 FRAME BASE MOUNTED SUBMERSIBLE, TANGENTIAL DISCHARGE

CABLE

Power and control cable are UL Listed and CSA Approved.

ELECTRICAL CONNECTION

Double-seal system with strain relief, consisting of a rubber grommet followed by epoxy. Individual wires have the insulation removed prior to epoxy potting to prevent wicking into the motor.

Wires are terminated with connectors secured to bronze lugs on the O-ring sealed terminal board. Stator and control leads from the motor are attached to the underside of the lugs.

SHAFT

Solid 416 stainless steel, precision machined to ensure a tight fit of the impeller and rotor onto the shaft.

MECHANICAL SEALS

Two separate tandem mounted seals to protect the motor from the pumped liquid. Upper seal is carbon against ceramic faces. Lower seal is silicon carbide against tungsten carbide faces.

IMPELLER

Enclosed axial flow design with blunt rounded leading edges and thick hydrofoil shape to pass large solids and stringy material. One-piece cast impellers are designed for circular flow to match in the equalizing-pressure, thick walled volute.

WEAR RINGS

Impeller and volute may be fitted with axial wear rings hardened to 300–350 Bhn or higher stainless steel.

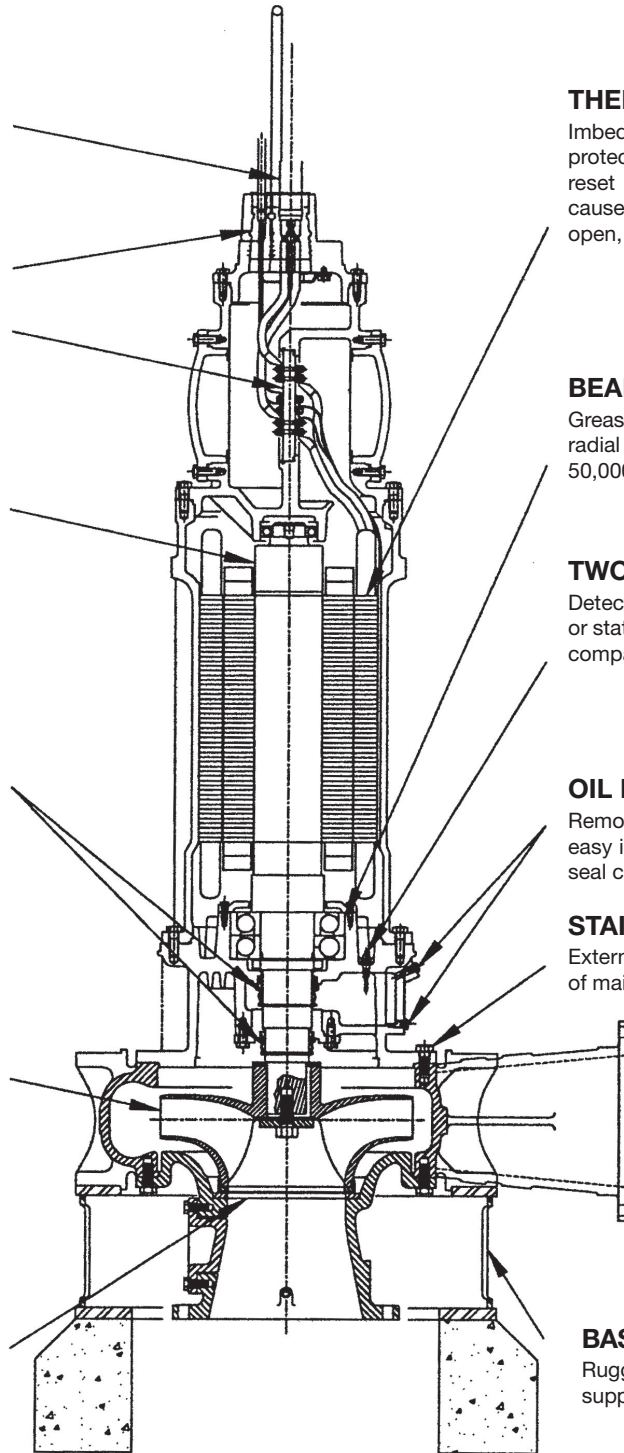

THERMOSTATS

Imbedded in the motor windings to protect from overheating. These devices reset automatically. Excessive heat will cause the normally closed contact to open, stopping the motor.

BEARING LIFE

Grease lubricated thrust bearing and radial bearing with an L10 bearing life of 50,000 hours at BEP.

TWO MOISTURE DETECTORS

Detects moisture entering the oil cavity or stator housing and sends a signal to a compatible controller.

OIL INSPECTION PLUGS

Removable O-ring sealed plugs for easy inspection and to change oil in the seal chamber.

STAINLESS STEEL BOLTS

External bolts are stainless steel for ease of maintenance.

BASE

Rugged heavy-duty base is designed to support the entire pumping unit.

Technical Data – 5730 WD 490 FRAME JACKETED DRY PIT SUBMERSIBLE, TANGENTIAL DISCHARGE

CABLE

Power and control cable are UL Listed and CSA Approved.

ELECTRICAL CONNECTION

Double-seal system with strain relief, consisting of a rubber grommet followed by epoxy. Individual wires have the insulation removed prior to epoxy potting to prevent wicking into the motor.

Wires are terminated with connectors secured to bronze lugs on the O-ring sealed terminal board. Stator and control leads from the motor are attached to the underside of the lugs.

SHAFT

Solid 416 stainless steel, precision machined, to ensure a tight fit of the impeller and rotor onto the shaft.

MECHANICAL SEALS

Two separate tandem mounted seals to protect the motor from the pumped liquid. Upper seal is carbon against ceramic faces. Lower seal is silicon carbide against tungsten carbide faces.

IMPELLER

Enclosed axial flow design with blunt rounded leading edges and thick hydrofoil shape to pass large solids and stringy material. One-piece cast impellers are designed for circular flow to match in the equalizing-pressure, thick walled volute.

WEAR RINGS

Impeller and volute may be fitted with axial wear rings hardened to 300–350 Bhn or higher stainless steel.

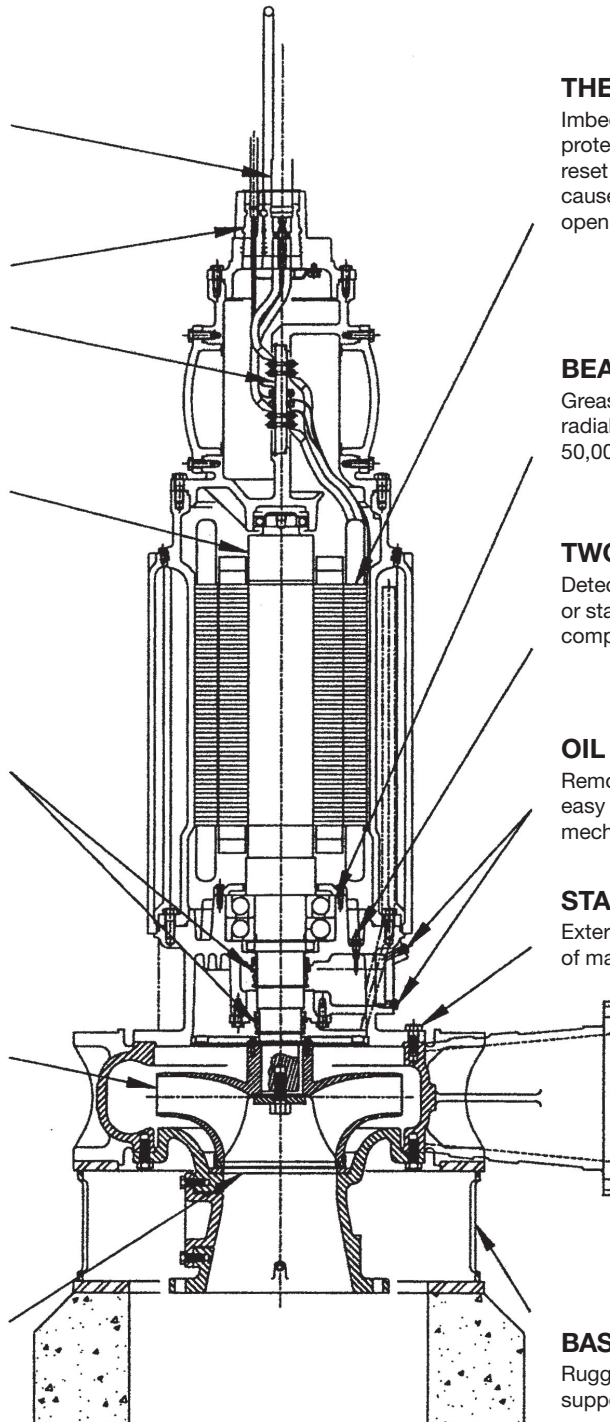

THERMOSTATS

Imbedded in the motor windings to protect from overheating. These devices reset automatically. Excessive heat will cause the normally closed contact to open, stopping the motor.

BEARING LIFE

Grease lubricated thrust bearing and radial bearing with an L10 bearing life of 50,000 hours at BEP.

TWO MOISTURE DETECTORS

Detects moisture entering the oil cavity or stator housing and sends a signal to a compatible controller.

OIL INSPECTION PLUGS

Removable O-ring sealed plugs for easy inspection and to change oil in the mechanical seal chamber.

STAINLESS STEEL BOLTS

External bolts are stainless steel for ease of maintenance.

BASE

Rugged heavy-duty base is designed to support the entire pumping unit.

Technical Data – 5730 MV, W and WD

Wet End	Vertical, mixed flow impeller
Rotation	CW or CCW as viewed looking down on pump, specify on order
Volute	Single, one-piece with countoured cleanout
Impeller	Single-suction, mixed flow, enclosed, solids-handling, with wear ring
Wear Rings	Radial type Axial type (optional) L Shape (optional)
Shaft	Integral motor, shims for impeller adjustment
Bearing Frame	Motor frame
Bearing Radial/Thrust	Integral motor
Lubrication – Seal	Oil
Motor	Vertical submersible, constant speed, squirrel cage, 3 phase, 60 Hz, 460 volt, 1.15 service factor, thermal protectors and moisture sensing probes
	Upper mechanical seal; carbon rotating face, ceramic stationary face
	Lower mechanical seal; silicon carbide rotating face, tungsten carbide stationary face
	Tungsten carbide rotating and silicon carbide stationary faces for upper mechanical seals (optional)
	Various voltages (optional)
	Continuous duty in air (optional)
	Continuous duty in air with water cooling jacket (optional)
	Viton® O-rings (optional)
Lifting Bail	Pull-up lifting bail (not supplied on WD pumps 365 frame or smaller)
D5731MV	
Volute	Single, one-piece with flush connections
Nozzles	Bottom suction - centerline discharge
Discharge Coupling	Slip on flange type
Discharge Base	Flanged inlet and flanged vertical discharge
Cable	Pull-up cable (optional)
D5731WD	
Fronthead	Separate one-piece casting, flanged for connection to suction elbow
Base Mount	Base and separate flanged suction elbow with cleanout
Pier Mount	Separate flanged suction elbow with cleanout (optional)
Nozzles	Bottom suction, side tangential discharge
Rotation	CCW when viewed from driver end (optional)
D5731CWD	
Base Mount	One-piece pedestal with integral suction elbow with cleanout

Technical Data – D5731 MV/W/WD & D5733 MV/W/WD

Pump Model	D5731 MV/W/WD						D5733 MV/W/WD
	Pump Size (Discharge Size)	12	14	16	18	20	24
Suction Size (Standard)	12	14	16	18	20	24	14
Nominal Wear Ring Clearance	.037	.039	.041	.042	.045	.060	.049
Impeller Fastener:							
Size	7/8 – 9	1-1/4 – 7	1-1/4 – 7	1-1/4 – 7	2-1/2 – 7	2-1/2 – 12	2-1/2 – 12
Tightening Torque (lb-ft)	150	350	350	525	950	950	1800
Impeller:							
Weight (lbs.)	104.50	*	★	X	#	▲	486.0
Inlet Area (sq. inches)	88.15	*	★	X	#	▲	144.3
WR ² (lb-ft ²)	15.0	**	★★	XX	##	▲▲	219
Sphere Size (maximum)	4-1/2	*	★	X	#	▲	4
Volute Cleanout Diameter	4-3/4	6	6	6	6	8	6
Max. Hydrostatic Test, PSI	75	75	75	75	75	75	225
Max. Casing Working, PSI	50	50	50	50	50	50	150
Nominal Casing Thickness	5/8	3/4	3/4	13/16	7/8	1	7/8
Max. Operating Temperature, °F	150	150	150	150	150	150	150

All dimensions are in inches

*	Impeller	L14A1A	L14A1D
	Weight	150.0	180.3
	Inlet Area	114.2	114.8
	Max. Sphere	5-1/4"	3-1/4"

★	Impeller	L16A1G	L16A1M
	Weight	245.0	270.0
	Inlet Area	146.7	150.0
	Max. Sphere	6"	3"

X	Impeller	L18A1H	L18A1M
	Weight	356.0	300.0
	Inlet Area	190.3	190.3
	Max. Sphere	4-1/4"	6-3/4"

#	Impeller	L20A1AU	L20A1S
	Weight	340.0	435.0
	Inlet Area	267.1	281.71
	Max. Sphere	4-3/8"	7-1/2"

▲	Impeller	L24A1L	L24A1BD	L24A1AM
	Weight	609.0	492.0	614.0
	Inlet Area	340.2	376.35	385.0
	Max. Sphere	9"	5-1/4"	3-3/8"

** Impeller WR²: L14A1A=31.0, L14A1D=32.2

★★ Impeller WR²: L16A1G=63.0, L16A1M=63.0

XX Impeller WR²: L18A1M=135.0, L18A1H=119.0

Impeller WR²: L20A1S=180.0, L20A1AU=137.0

▲▲ Impeller WR²: L24A1G=320.0, L24A1BD=296.0, L24A1AM=283.0

MV style pumps do not have volute cleanout

These are maximum values based on standard construction. If higher values are required, contact the factory.

THIS PAGE INTENTIONALLY LEFT BLANK